

# **BIANCO** **iCON** **SERIES TANKZ**

Please ensure you read and understand the instructions before installation.



INSTALLATION INSTRUCTIONS  
(iCON250; iCON600; iCON900; iCON1200)

## **General safety instructions**

### **Safety**

As Work, Health and Safety Legislation differs in each state and territory, it is necessary to refer to all relevant Work, Health and Safety legislation, regulations and Australian standards in your state or territory at all times during installation, assembly, servicing and repair of the iCON tank systems.

Current statutory regulations and all relevant Australian standards must be taken into consideration at all times.

The system and any of its individual parts must be installed by a licenced person. Installation by a non-licenced person may void warranty.

The entire system must be shut down before any maintenance can be undertaken. Once maintenance is completed the tank must be properly sealed/locked by means provided with the tank to prevent future unauthorized entry.

We offer a wide range of accessories which all match each other. The use of non-authentic accessories may void the warranty and can indemnify us against any subsequent claims of liability from any resulting damages.

### **Identifications of water pipes and outlets**

All service water pipes and outlets leading from the iCON water tank must be identified in accordance with Australian regulations and other relevant local plumbing regulations to avoid inadvertent connection with drinking water supply.

In order to avoid the wrong connection between the drinking water and the rain water pipe work, all conduits and rain water taps are to be clearly marked with "RAINWATER" in writing and must be in accordance with local standards.

All non-drinking tank water outlets should be clearly marked "RAINWATER" and we recommend that vandal proof taps be installed.

### **Maintenance**

In the event that work needs to be carried out inside the tank, local Work, Health and Safety legislation for work in confined spaces must be followed.

### **Site**

Work, Health and Safety legislation for the local area must be followed for excavation and trenching and use of equipment for the installation of the tank.

### **Lifting of tanks**

Local Work, Health and Safety legislation must be followed when lifting, handling or moving iCON water tanks.

### **Protection of site**

It is the responsibility of the installing contractor and the property owner to ensure that the area where the tank/tanks are installed is protected against damage by third parties during and after the completion of the installation. E.g. keep heavy vehicles out of the construction area.

### **Future landscaping works**

When locating the tank, ensure you take into consideration the location and positioning of future landscaping features such as garden beds, paths, driveways, brick walls etc.

**Technical Data**

**iCON250**

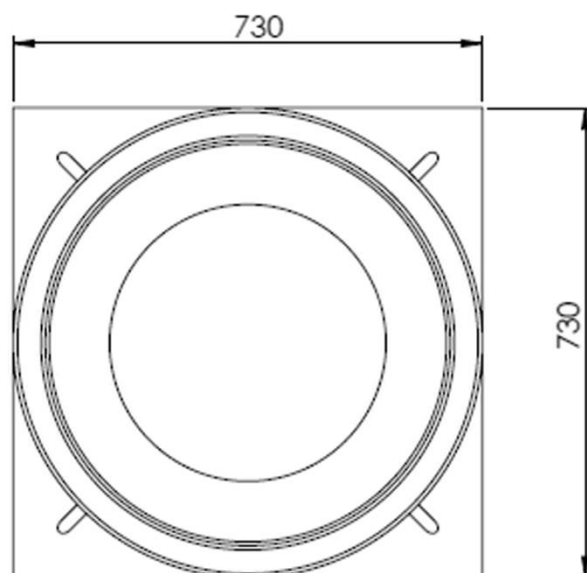
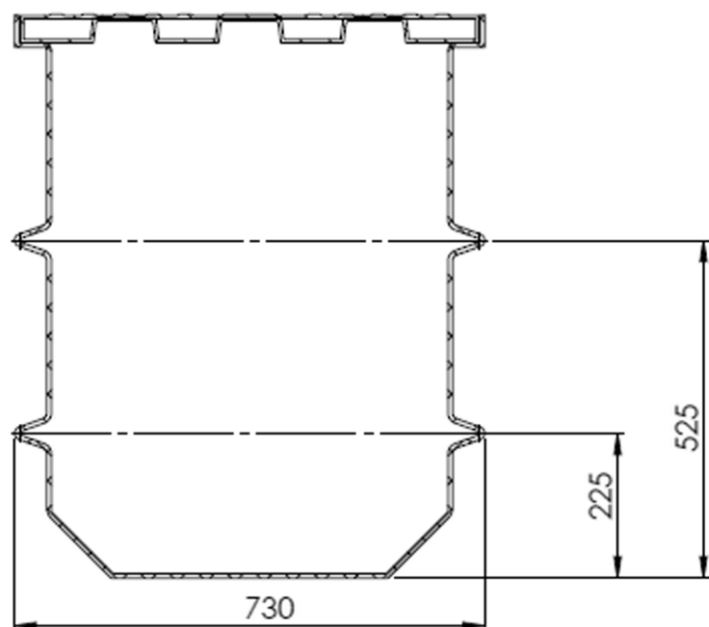
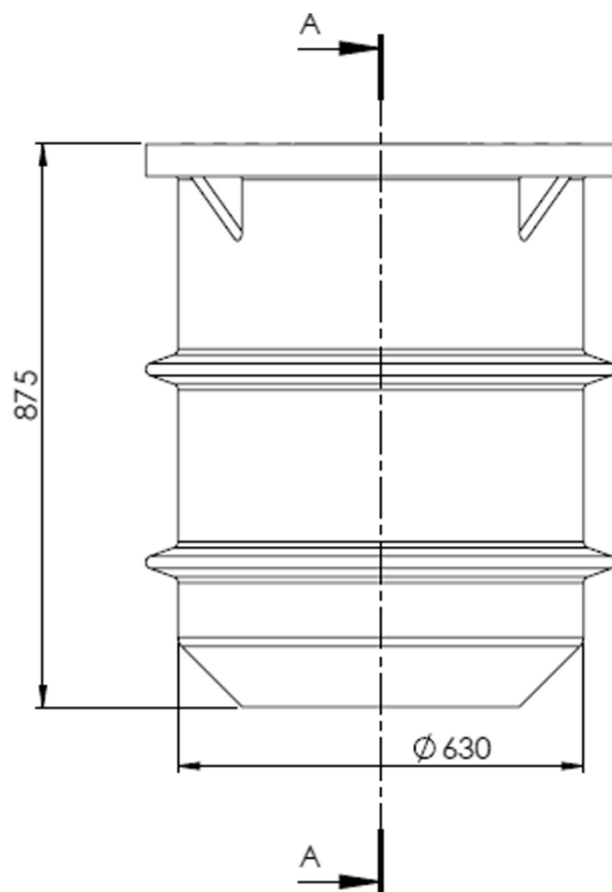

**iCON600**

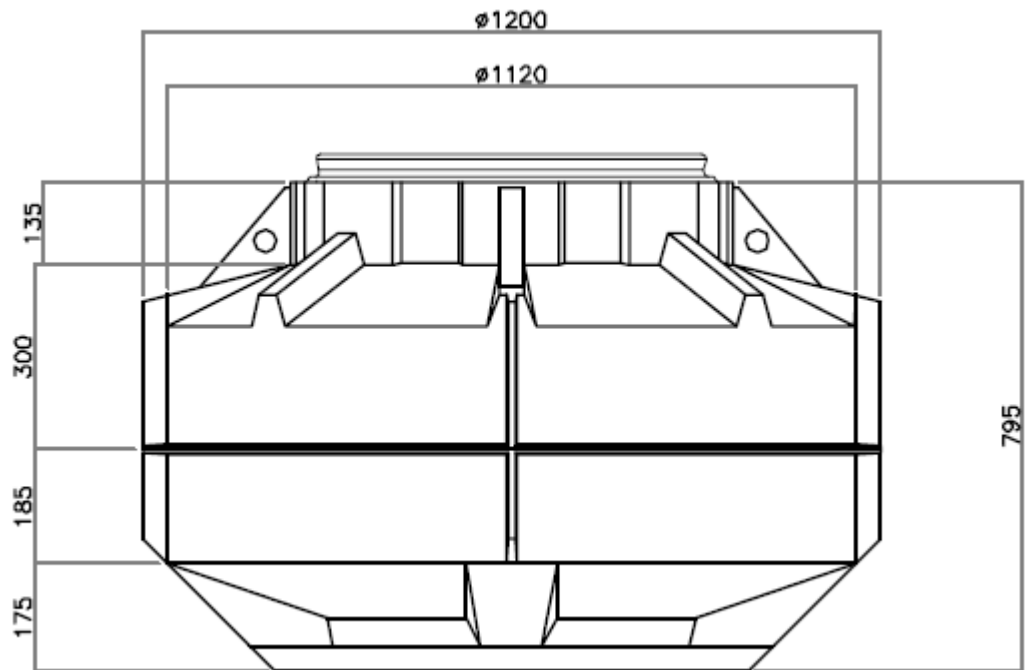
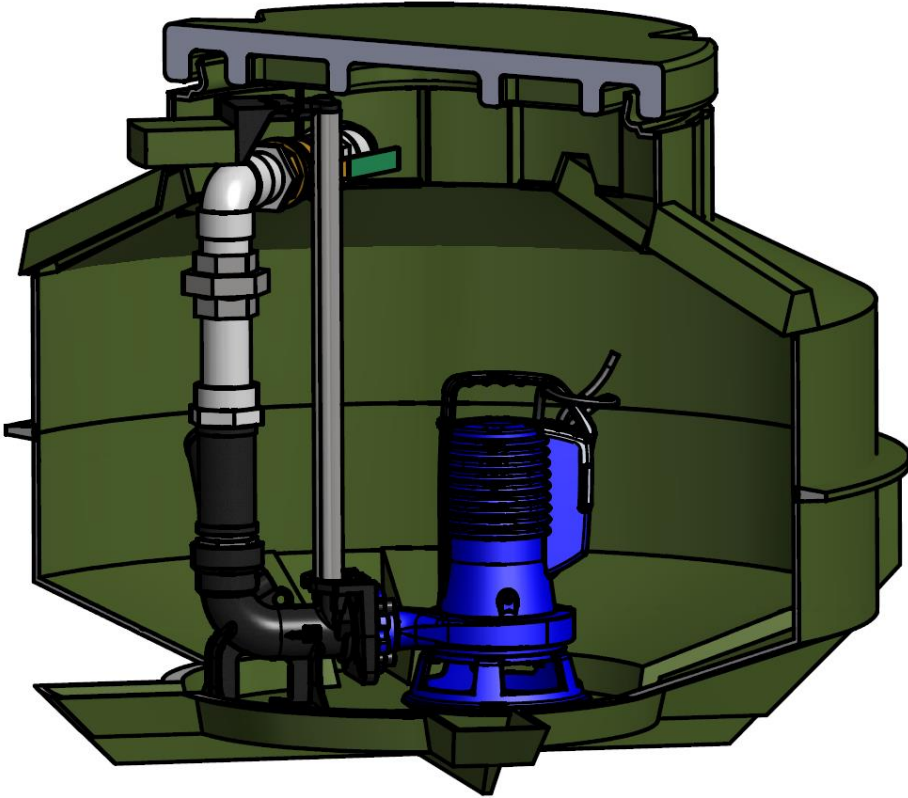

**iCON900**

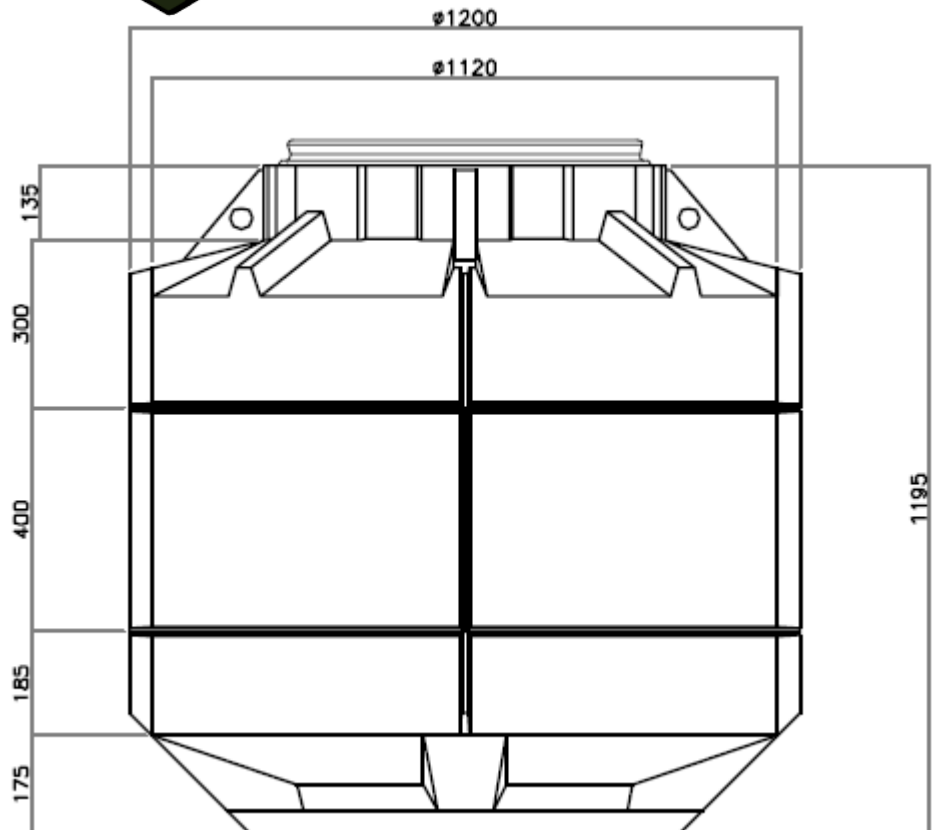
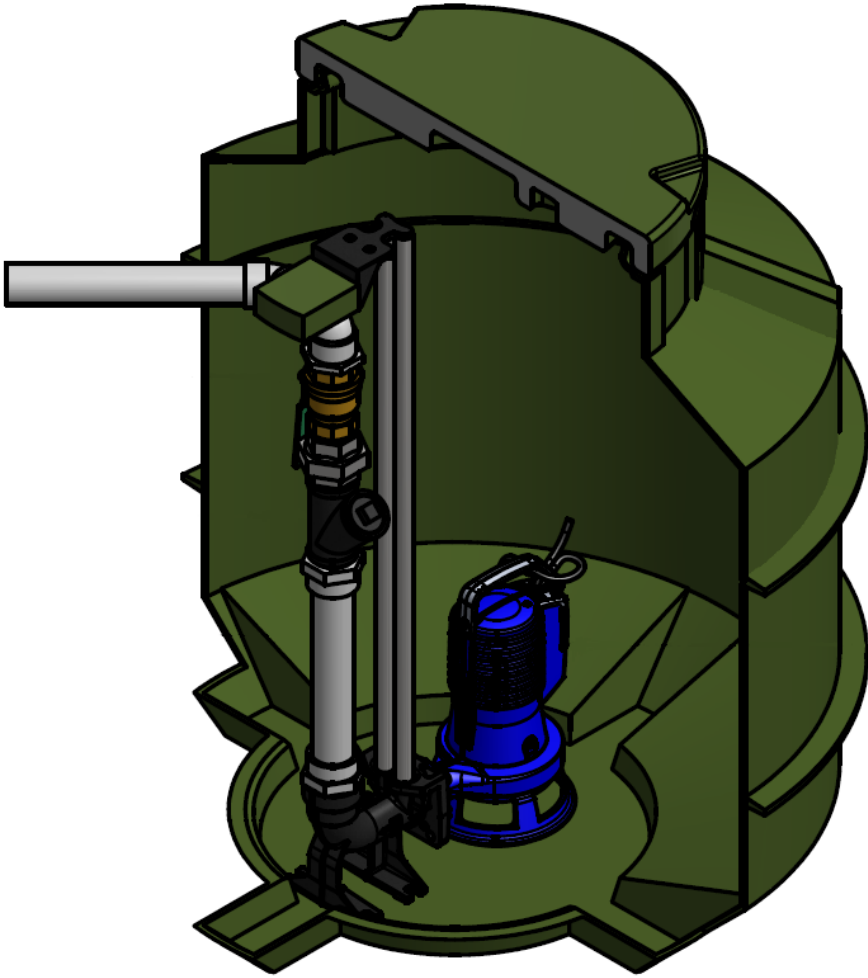

**iCON1200**

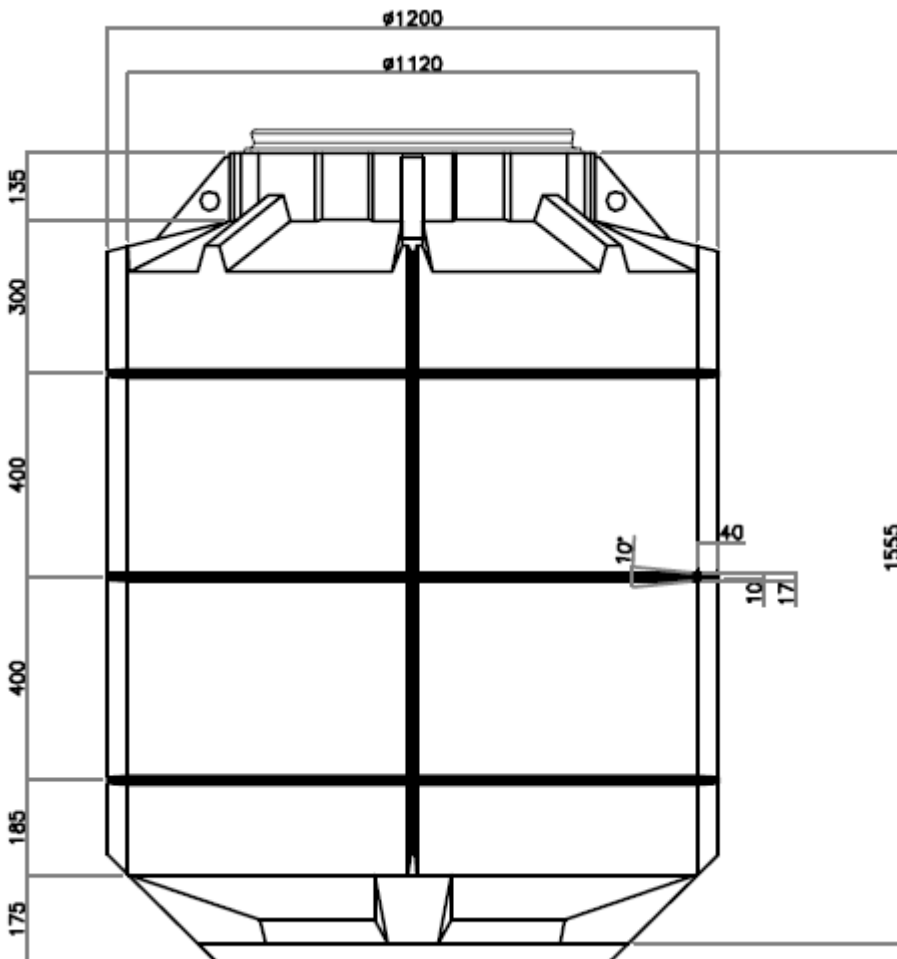
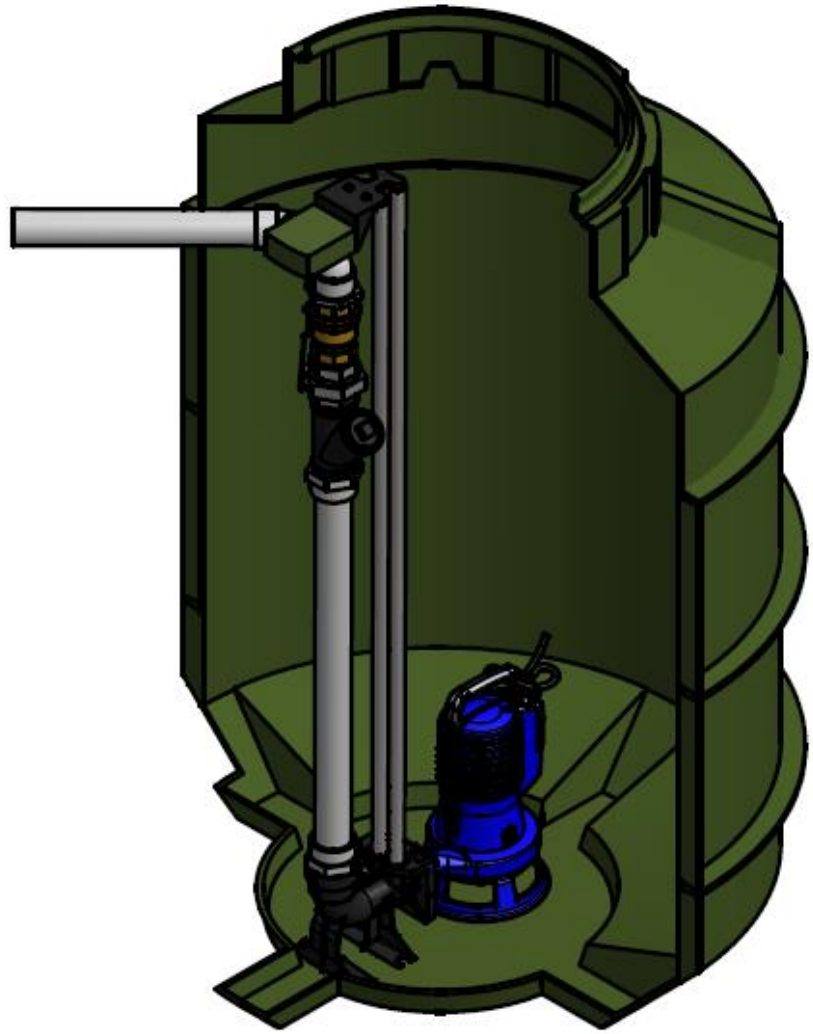

Your iCON packaged pump station will give you many years of service with proper care and complying with a few simple guidelines.

Only qualified tradesmen and personnel should install, repair or operate your pump station. Any electrical wiring must be performed by a qualified electrician.

Before installation commences, please consult your local authorities for all applicable codes and regulations.  
Prior to installation – Installers checklist

### **Safety**

Ensure installer is aware of confined spaces guidelines.

Make sure that there is sufficient oxygen and that no poisonous gasses are present.

Check the risk of explosion before using electric hand tools.

Do not ignore health hazards and observe strict cleanliness.

Ensure that all lifting equipment is in good condition.

All personnel working with sewage must be vaccinated against diseases that can occur.

Always keep a first aid kit handy.

Before installing the pump station, check the depth of the inlet pipe, as this will determine the tank depth (see tank inlet specification.)

### **Caution:**

Experienced and qualified tradesmen must carry out installation.

Before digging, call all relevant authorities to locate any underground services.

The installation of a pump station requires prior approval of local authorities. Questions relating to this must be directed to a responsible officer of local council and/or other relevant authority.

### **The following information must be regarded as a guide only.**

Determine the best location for your tank, and control panel (if applicable).

Correct appraisal of site conditions is essential before installation of sewage and storm water tanks. Installers must recognize that these tanks when empty will float on approximately 50mm of water. The upward thrust at the base of the tank fully immersed in water could exceed 69.000kPa. Close consideration to site conditions is therefore necessary.

- Consider drainage, particularly at the tank base.
- The rise in water due to tidal conditions, saturation of the ground during heavy rain and likelihood of flooding or run-off water from any source.
- The quality of available back fill.

Where tanks are installed under adverse site conditions, the utmost care is required to prevent any chance of the vessel being forced out of the ground by upward pressure of the water. This can occur if the base is not properly drained.

For installations where the water table is above the bottom of the tank, it is recommended that the tanks be bedded using cement slurry (see installation procedure). This will prevent the base of the tank buckling.

Check for any damage to tanks. During transport and handling over rough ground, be careful to avoid “bruising”. Contact with sharp stones or dropping of the tank may result in fractures, which must be repaired before installation to prevent leakage through the tank wall.

Minimise the use of elbows on the inlet line, If required, use only 45 elbows.

Plan your installation location carefully to ensure that the inlet pipe stays within the allowable inlet height.

Determine where the incoming power will be supplied from, and if it can handle the rated load for your pump station

Mount the control panel, when applicable, in accordance with electrical codes and where the alarm light can be easily seen.

Make sure you have all the necessary equipment and supplies before starting your installation.

Determine the length of electrical cable required, as all joints in cables must be made by approved submersible splice. Only extend cables with cable of equal or greater submersion rating and current carrying capacity.

### **Procedure for installation**

The hole for the tank should be no greater than 250mm to 300mm oversize to tank diameter, with due regard to the amount of concrete or backfill to be used under and around the tanks.

It is suggested the base of the hole be drained especially in water charged ground, before, during and until concrete encasement has set, to hold the tank securely in the ground.

Lay minimum of 100mm of 20m.P.a concrete in the bottom of the hole.

Lower the tank into the hole, while concrete is still slurry. Ensure no rocks or sharp objects fall into the hole as damage to the tank wall and base could occur.

Where locking holes are provided in the base of the tank, fit reo bar so it penetrates the concrete slurry to stop the tank base moving.

Level and adjust the tank to suit installation conditions.

Fill tank with water up to at least 300mm-400mm depth.

Secure tank with stabilizing bars or timbers to hold in place before encasing with concrete.

Put pumps into tank and connect unions (where fitted) before installing discharge line, to make sure connections are free and level.

The tanks are provided with a collar approximately 360mm from the base. The purpose of this collar is to create a bond between the tank and the backfill material to withstand the upward forces when the tanks are empty.

Check local council and other authority's requirements concerning level. Ensure you have relevant inspector's approval before back filling commences.

Whilst site conditions will determine the amount of concrete encasement, you should refer to engineer's instructions for each individual site.

Backfill material must not exceed 100mm to underside of lid when fitted with gatic type concrete in-fill lid.

When backfilling use sand or soil only. At all times, be careful that rocky or sharp objects are not used. Avoid use of heavy soils that do not consolidate.

Inlet pipes must be vented.

Inlet pipes must be fitted with a t junction and dropper pipe on the inside of the tank.

All pipe connections t tanks must be flanged and sealed to stop water and dirt ingress.

Minimum inlet height from base of tank to underside of pipe would be 600mm.

### **Trafficable Lid Installation**

The Bianco iCON Underground Tank with the cast iron cover and frame are suitable for installation in trafficable areas to the rating of the lid (Class B or Class D). Load ratings beyond Class D are not available.

When the tank is installed with or without a riser (optional) in areas traversed by traffic, the upper section must be embedded and supported by reinforced concrete (with suitable load classification). The concrete encasement must be uninterrupted, 300 mm wide and approximately 200 mm deep. Subsequently, the frame is encased in concrete as shown and the cast iron cover supplied with the product is fitted on the frame.

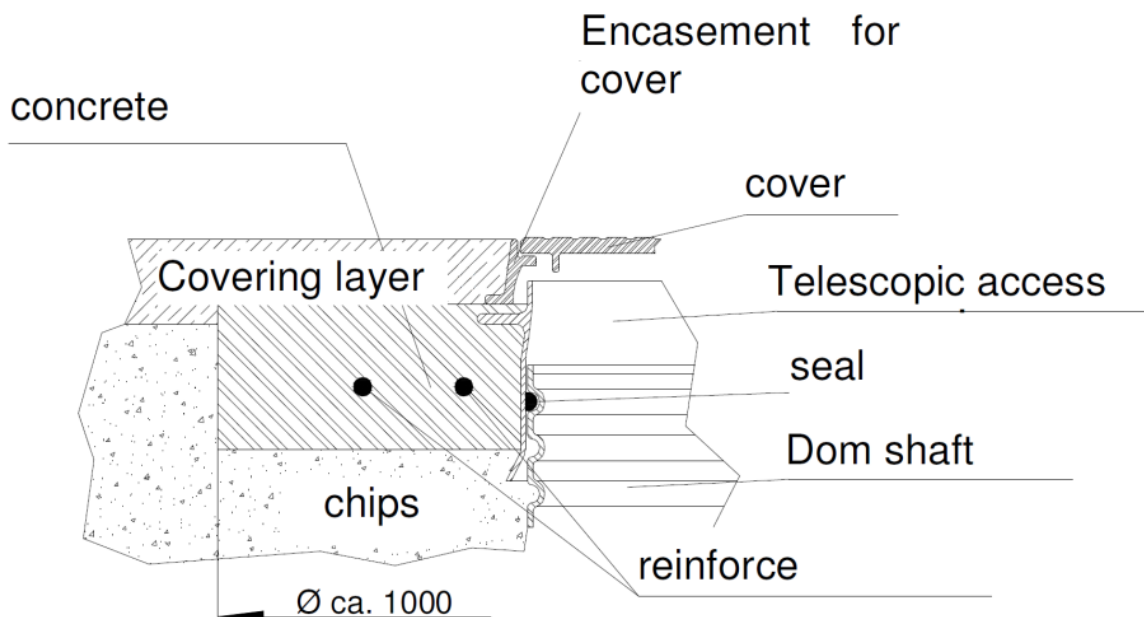



### **After installation**

Ensure that the tank is protected from accidental contact by motor vehicles, construction or farm equipment, or wandering livestock. Where there is danger of stock being able to walk on the lid, the tank must be fenced off to prevent the risk of the lid being holed, or injury to livestock. Alternatively, a specially constructed lid able to withstand the required traffic can be supplied; it is preferable for this to be specified prior to purchase.

Installation procedures may vary from site to site and with different model tanks and pumps. Please read installation instructions carefully. If in doubt please refer to Engineers Department.

Safety precautions – Use, care in the operation of packaged pump station

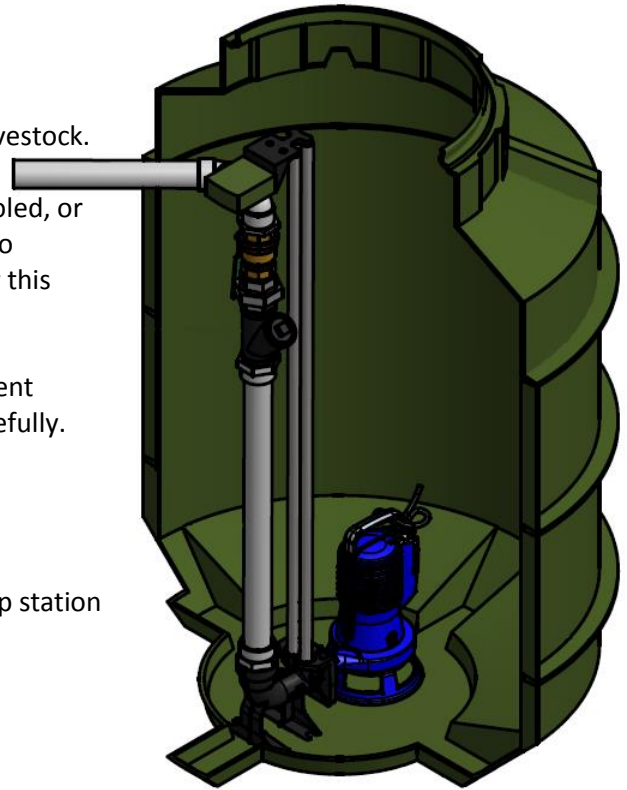

Your wastewater disposal service is part of a low-pressure sewer system. The key element in this system is the packaged pump station. The tank collects all wastewater; solids in the sewage/trade waste/effluent are then processed into slurry suitable for pumping. The pump generates sufficient pressure to pump this slurry to the sewer main.

### **Points to remember:**

- Minimize the amount of cooking grease entering the system.
- Regulatory agencies recommend that the following items should not be introduced into any sewer, either directly or through a pumping state:
  - Glass
  - Metal
  - Baby napkins
  - Socks, rags or cloth
  - Plastic objects (e.g. toys, utensils etc.)
  - Sanitary napkins or tampons
- In addition you must NEVER introduce into any sewer
  - Explosives
  - Flammable material
  - Lubricating oil and/or grease
  - Strong chemicals
  - Petrol or gasoline
- Do not leave cover off the tank except when servicing, to prevent the entry of foreign materials such as rocks, metal, soil, animals or humans.
- Prevent infiltration or direct flow of rain or run-off water into the tank to minimise pump cycling, this will prevent overloading the treatment facility and will facilitate swift transportation of waste/sewage/effluent.
- To reduce the risk of electrical shock, pumps and control panels must be properly earthed in accordance with AS3000 wiring rules and all applicable state or local council ordinances.
- During power blackouts, minimise water consumption in the building to prevent sewage backing up.
- Always keep the shut off valve completely open when the system is in operation (unless advised otherwise by proper authorities). Before removing the pump from the station, be sure to close the shut off valve. (This prevents backflow from the pressure sewer.)
- Keep the control panel (if installed) locked or confined to prevent unauthorized access.
- If the pump is idle for long periods of time, it is advisable to start the pump occasionally by adding water to the tank.

## **Breakdown – Safety when Servicing**

Be aware of confined spaces guidelines.

To reduce the risk of electrical shock, always disconnect the pump from the power source before handling or servicing. Lock out power and tag.

Do not wear loose clothing that may become entangled in the impeller or other moving parts.

Keep clear of suction and discharge openings. **DO NOT** insert fingers in the pump whilst power is connected.

Always wear appropriate safety gear such as safety glasses when working on the pump or piping.

Cable should be protected at all times to avoid punctures, cuts bruises and abrasions. **INSPECT FREQUENTLY.**

Never handle connected power leads with wet hands.

To reduce the risk of electrical shock, all wiring and junction connections should be made in accordance with local codes and regulations.

## **The Submersible Pump**

### **Warning**

Only qualified and competent trades' people should attempt installation or other work on the submersible pump and its associated equipment.

All necessary care should be taken to avoid electric shock. Do not work on or touch your electric submersible pump, or anything in electrical contact (e.g. water in pit), unless the system has first been electrically isolated.

Do not enter the pit without all necessary safety equipment for confined spaces.

Do not leave open pit unattended or barricaded.

Incorrect operation of application of the submersible pump could cause personal injury or damage to the pump.

### **Taking delivery of the submersible pump**

Please ensure all parts ordered/requested have been delivered and delivery paperwork and instruction manuals are complete.

Inspect pumps and equipment for any signs of damage

Take notice of any warnings stickers/labels.

### **Storage**

Store your equipment securely in an area protected from damage by vandals, weather or other construction persons or equipment.

Avoid long-term storage of the pumps in the pit during construction period prior to commissioning.

Do not allow electrical leads to become immersed in water.

### **Installation**

The installation of the pumping equipment must only be carried out by a suitable qualified and competent tradesperson.

### **Pits and tanks:**

For tanks and pits supplied as part of the package, please refer to the packaged pump station, section 1

In general, the pit should be dimensioned according to the relation between the water flow into the pit and the pump capacity. Also, consideration should be made of the physical dimensions of the pump and enough room allowed for any control gear, float switches etc. to operate freely when determining both the pit depth and area.

The pit walls, floor and ceiling must be constructed of a suitably solid material or designed to prevent silt, mud, rock or other foreign objects from entering the pit.

Pit lids and grates must also be designed to prevent entry of silt, mud, rocks or other foreign objects.

Be sure to provide adequate access to the pumps and their associated valves etc.

A dedicated vent pipe direct to the tank must adequately vent pits with sealed or gas-tight lids.

### **Pump positioning:**

The pump should be mounted on a firm solid surface away from inlet pipes etc. and if possible, elevated by 100mm from the base of the pit. Do not hang pump from discharge pipe work, lifting chain or electrical cable.

Secure the pump with a lifting chain or other suitable means of top of the pit at the manhole to prevent the pump from tipping over or walking on the pit floor. **The pump should never be lifted by the power cable!** Allow enough free cable in the pit to enable the pump to be lifted out of the manhole without electrical disconnection. This free cable should be coiled neatly and attached to the lifting chain at the top of the pit. The pit should be cleaned totally of silt, mud and other foreign objects prior to pump installation and be kept clean following this. (See care and maintenance sect.22)

**Pipe work**

Rigid PVC pipe work (minimum Class 9 pressure pipe) should be used in preference to flexible hose. Non- pressure rated pipe or hose should not be used. An isolating valve and barrel union/quick coupling should be provided on each pump discharge line before connection to the common discharge line

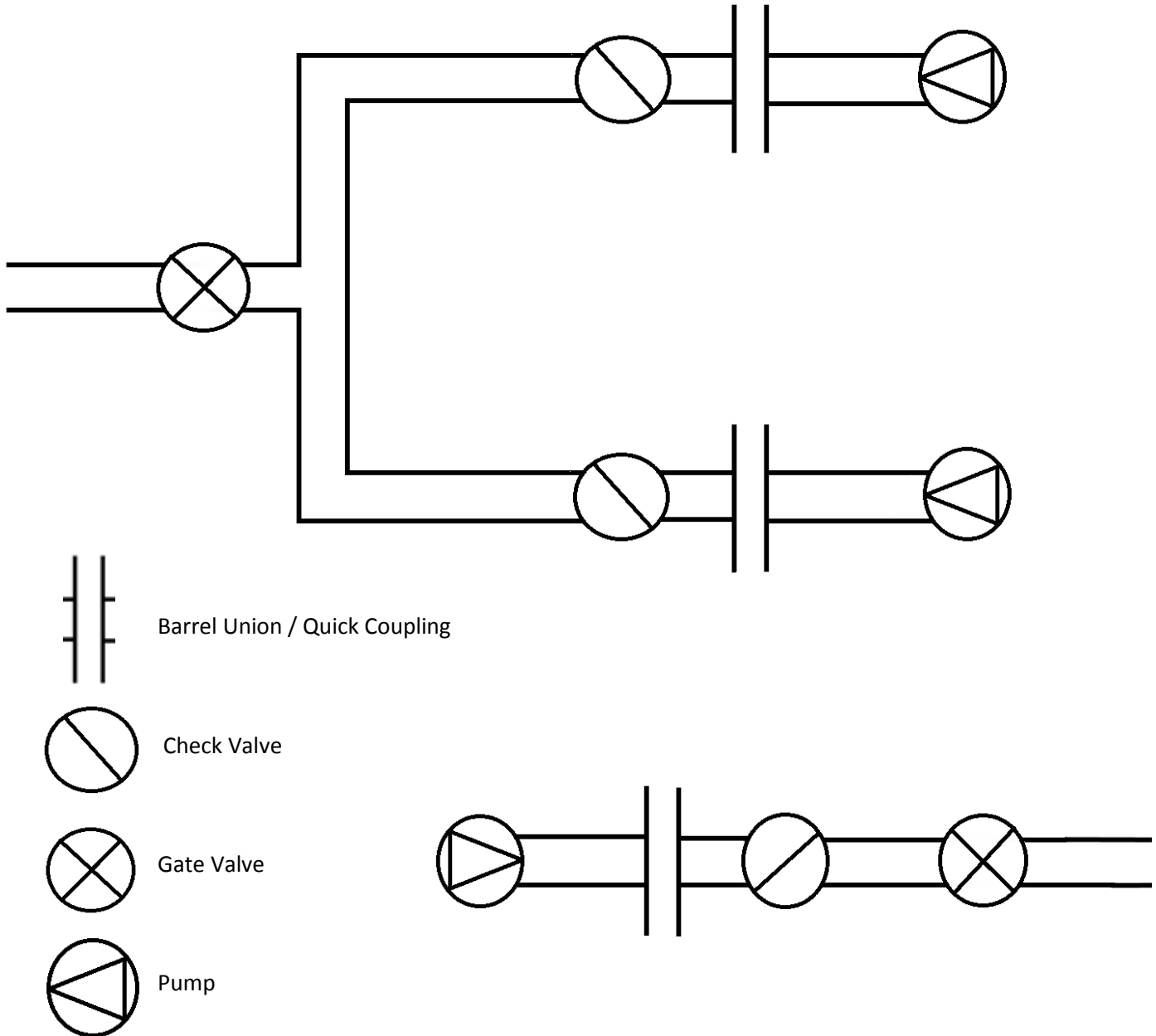

Note: Ball type non return valves should be used in sewage application.

The valves and unions must be located as close as practical to the top of the pit at the manhole. Pipe size should generally be calculated by the system flow rate and length of run employing accepted methods and principles, however, pipe work should be at least the same size as the pump discharge connection.

## Pump Controls

### General

Care should be taken to ensure that the adjustments of the float level controls are correct. Cycling (excessive starting and stopping) and dry running void will warranty.

### Float switch types

#### Differential

These float switches operate when tilted at approximately 45° up or down. They can be used as direct on line controls for single phase pumps up to 10 amps, or as signal controls. For use as signal controls, differential floats should be anchored approximately 100mm from the float head as shown below.

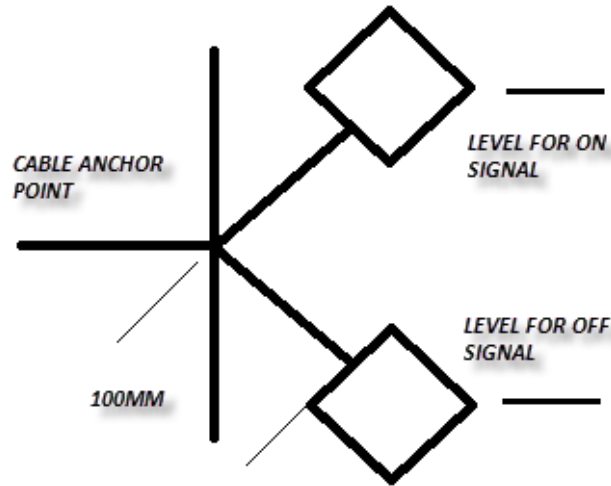

Be careful to position the float switch according to whether it is to provide an “On” signal or an “Off” signal. For use as direct on line or differential control, the length from the head to the anchor point determines the depth of the differential.

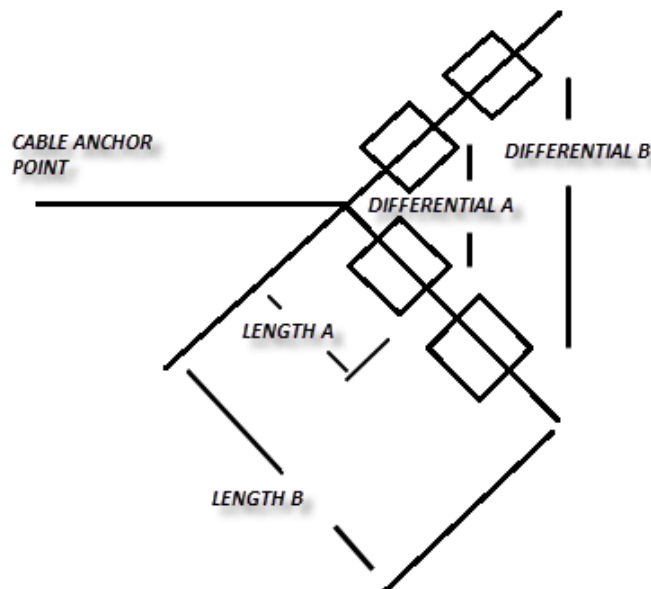

Ensure that the float will not tangle on any other equipment in the pit.

Some differential floats may have provision for normally closed operation or normally open operation. Read the manufacturer’s literature or test with a continuity tester to determine this.

Ensure that all unused active conductors are terminated safely.

### **CR type float switch**

These float switches are only used as signal controls. They work on a differential of 2° and therefore should be anchored at the position of the required signal.



### **Single pump integrated float switch**

Ensure that the float switch cable is attached to the pump by the clip/bracket provided. The float switch should be adjusted as per the manufacturer's specification, however, a standard arrangement is shown below as a guide

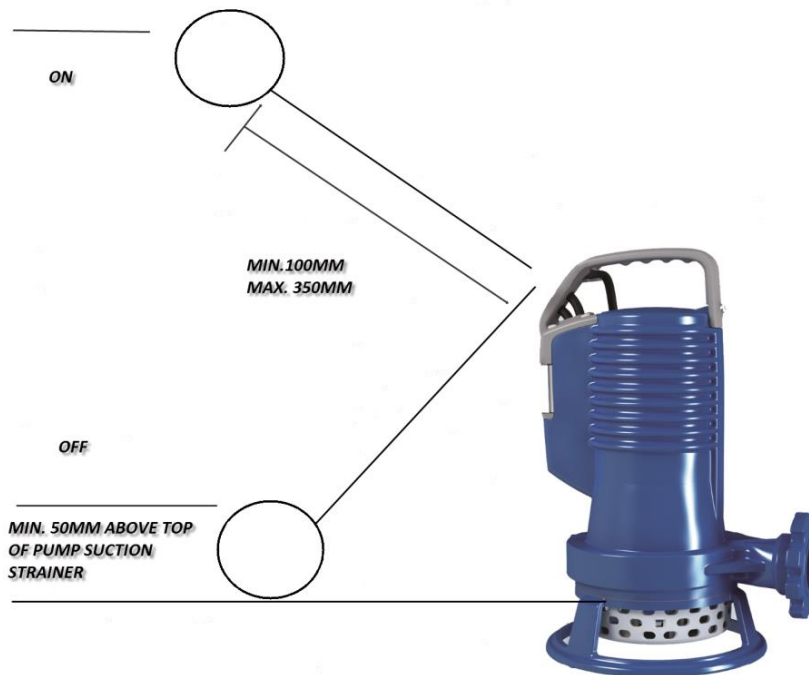

### **Single pump, separate float switch**

The float switch should be free to move as for integrated float switch and adjusted similarly with the addition that, where a mounting clip/bracket is not provided, the float switch cable should be anchored securely by cable tie or similar at the pivot point to the discharge pipework, body of the pump or other similar anchor point. Consideration should be made for the ease of removal of the float switch from the pit for inspection in the case of the pit flooding. Excess cable should be coiled neatly and attached to a suitable point at the manhole.

## Dual pump kits

It is your responsibility to ensure the control gear is suitably set up to protect the pumps from cycling and dry running. As an option a dual pump kit comprising the float switches mounted in a conduit or bracket manufactured to the approximate dimensions of the tank can be supplied. This float set should be checked for accuracy of dimensions and float switch adjustment and a adjusted as necessary, insert figure

Mount the conduit on a hook or similar bracket at the manhole ensuring that the conduit is held securely but is easily removable from the pit as a complete unit for maintenance. Be careful to position the float set away from obstructions to allow free movement of the float switches. Allow enough loose cable in the pit for the float set to be completely removed from the pit manhole. Coil this neatly and attach at the manhole.

Warning: do not allow the liquid level to drop below the suction inlet of the pump. Dry running will void the warranty.

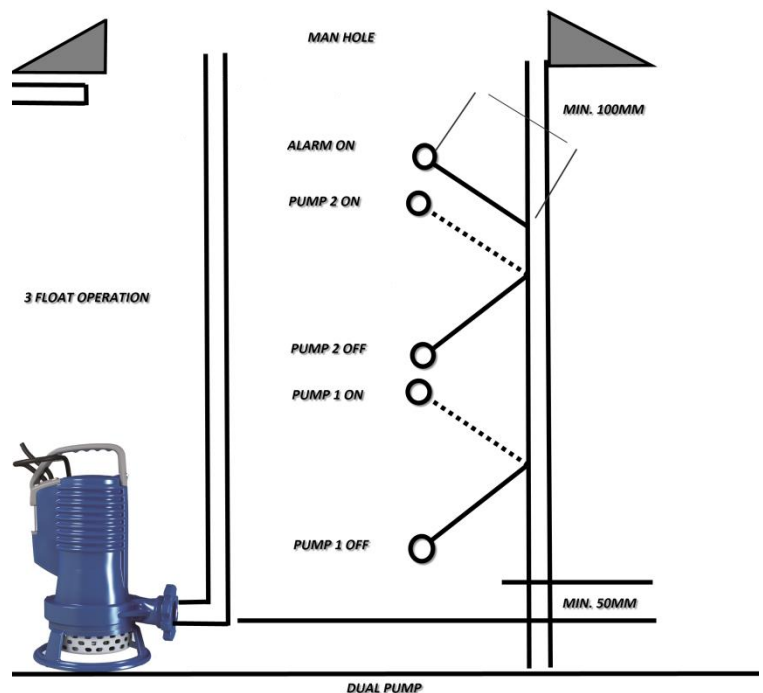
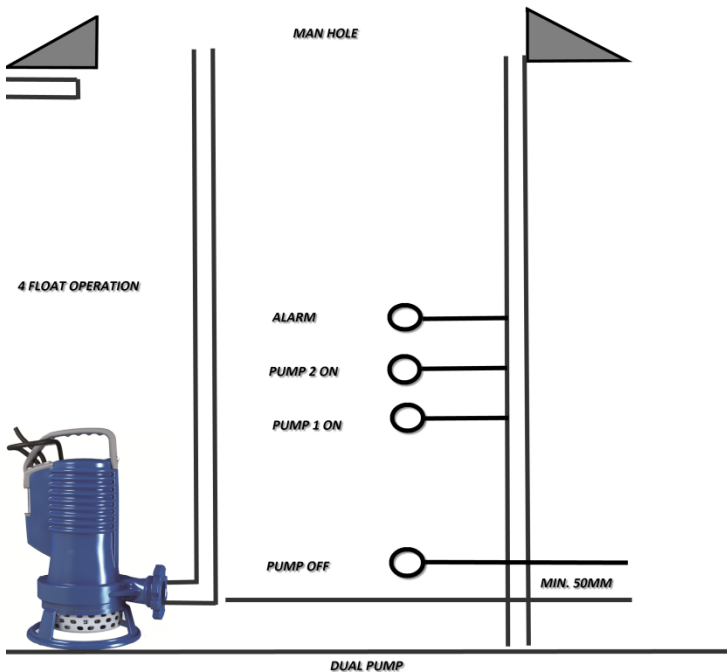
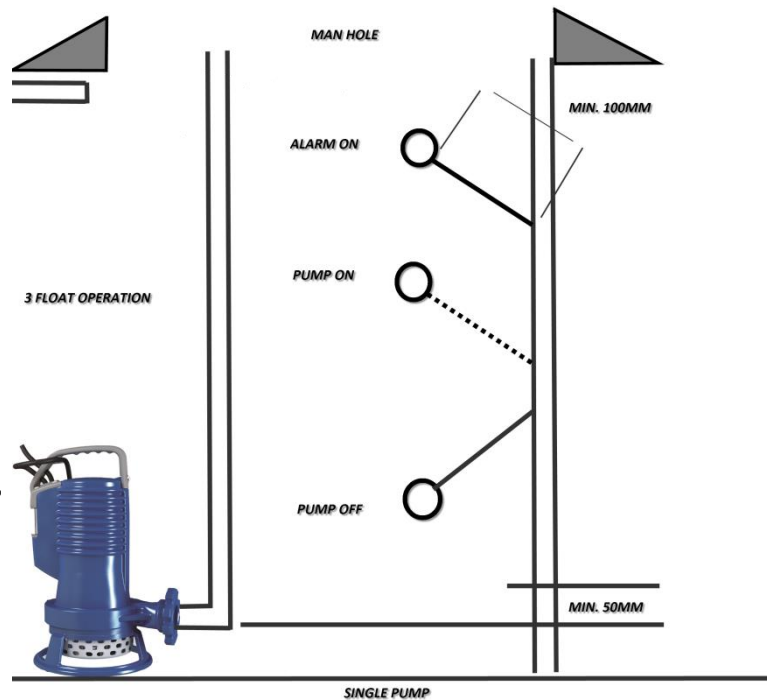
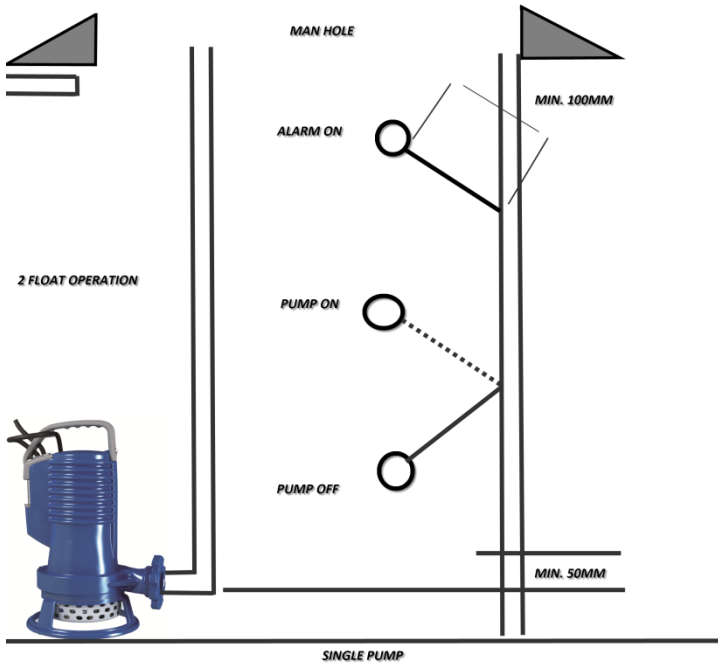

## **Electrical connection**

ELECTRICAL WORK MUST ONLY BE PERFORMED BY A QUALIFIED AND COMPETANT ELECTRICIAN  
ELECTRICAL CONNECTION SHOULD BE CARRIED OUT IN ACCORDANCE WITH LOCAL REGULATIONS.  
READ ALL WIRING DIAGRAMS AND INSTRUCTION SHEETS SUPPLIED BEFORE ATTEMPTING ELECTRICAL CONNECTION. IF IN DOUBT, CONTACT THE SUPPLIER FOR ADVICE AND COPIES OF WIRING DIAGRAMS OR INSTRUCTION SHEETS.

## **Supply**

Ensure available power supply complies with electrical data on pump and control panel nameplates.  
Power must be supplied via a main isolating switch. If the pump is not installed close to the switch, it must be a lockable type.  
Three phase pumps must be connected through a hand resettable thermal overload.  
All internally fitted thermal overloads and thermistors must be connected as per the manufacturer's instructions.  
A clearly marked dedicated circuit of an adequate capacity must be used. Pay careful attention to potential voltage drop.

## **Control Panels**

Connection to control panels must be made as per instruction sheets and wiring diagrams supplied. Generally, float switch cables, if supplied in a conduit as a set are marked by tags on the end of the cable.  
All unused wires are to be terminated in insulated connectors.  
Mount control panels in a vibration free position as close as practical to the pit. Allow at least 1m x 1m clear standing space in front of the control panel and position well away from possible damage by vehicles/machinery etc.  
Thermal overloads fitted should be adjusted to full load amps noted on pump nameplate.  
For three phase pumps, check direction of rotation. Correct rotation is clockwise looking down from on top of the pump or anti-clockwise looking at the impeller from the bottom. Swap any two phases to change rotation. To visually inspect direction of impeller rotation, it may be necessary to remove the suction strainer. Keep clear of the unprotected impeller.

## **Conduits**

All wiring from control panel to pit must be in approved conduit or trunking.  
Conduits from pit to control panel must be adequately sized with a minimum amount of bends to allow easy insertion and withdrawal of cables. Minimum 2 x 32mm or 1 x 50mm conduit with long radius bends is standard procedure for dual systems to 1/5kW  
All conduits entering control panel must be sealed internally with silicon or similar to prevent ingress of moisture from the pit.

## **Cables**

### **DO NOT ALLOW CABLE ENDS TO BE SUBMERSED**

An approved submersible splice must make joints in cables. Only extend cables with cable of equal or greater submersion rating and current carrying capacity.  
Leave enough slack cable in the pit to allow easy and complete removal of equipment from the pit. Ensure that this loose cable is secured at the pit manhole to prevent float switch fouling or entry into pump impeller.

## **Commissioning**

### **General commissioning procedure**

Double check all aspects and details covered by this document.  
Check all electrical connections are complete and correct.  
Check adequacy of power supply. Switch on all isolating switches.  
Double check pump rotation.  
Check amp draw of motors. Compare to nameplate details.  
Ensure pit is clear of silt, mud, building debris and other foreign objects.  
Double check thermal overload setting  
Run through complete system operation ensuring that pumps switch off before running dry or sucking air  
Return all selector switches to auto operation.

## **Operation**

In general, with correct control settings, the system should operate automatically.

Do not allow anything to enter the system pipe work or pit for which the pump is not designed to pump.

## **Storm water/Subsoil drainage pumps**

Unless otherwise specified in writing, these pumps are only designed to pump slightly silty water, not leaves, twigs, large quantities of mud, gravel or other foreign objects.

## **Sewage Pumps**

These pumps are designed to pump liquids and soft solids classified as normal sewage. Under no circumstances should articles of clothing, sanitary items, rags or other foreign objects be allowed to enter the system pipework or pit.

## **Make sure regular maintenance is carried out on the entire system**

### **Trouble shooting guide**

#### **Pump motor does not run**

Water level in pit below the off level float.

Power failure. Check isolating switches and circuit breakers and fuses

Thermal motor protection is set too low. Adjust and reset.

Loose terminal connection.

Float switch movement obstructed.

#### **Motor trips circuit breakers or thermal overload after short time of operation**

Temperature of pumped liquid is too high.

Impeller jammed or partly jammed by foreign objects

Phase failure

Voltage too low

Impeller corroded to cover plate from lack of use or moisture entry during storage

#### **Pump runs but does not pump**

Gate valve closed

Suction strainer or discharge pipe blocked

Pump too small for application

Incorrect direction of rotation

Air lock in pump. Check that pump does not suck air before switching off. Vent discharge pipe below check valve.

#### **Pump will not switch off after emptying tank**

Off float adjusted too low.

Incorrect wiring

Float switch fused

Off float switch movement obscured.

Repeated banging sound after pump switches off or tank continues emptying after pump switches off.

Discharge pipe siphoning. Check that discharge point is not lower than pump

## **Care and Maintenance**

ONLY QUALIFIED AND COMPETENT PERSONNEL SHOULD ATTEMPT TO CARRY OUT MAINTENANCE WORKS ON YOUR SUBMERSIBLE PUMP SYSTEM.

Installation conditions will determine regularity of maintenance intervals. However, all installations should be serviced once every six months. More regular servicing is required for applications where there are abrasive particles in the water, excessive silt or debris entering the pit, or where the pumps are subject to heavy usage.

It is a good idea to keep a close eye on your newly installed system until the time of the first maintenance service, to determine if more regular servicing is required.

Particular care should be taken to keep the pit clean while construction works are in progress.



Maintenance schedule – in addition to any requirements in manufacturers' manuals  
Be careful to avoid electric shock. Isolate pumps and controls before starting work.  
Check external condition of pumps and control gear  
Check pumps for wear  
Check condition of electrical equipment  
Check pit for sludge build up and presence of foreign objects and remove if necessary.  
Check that pump cables are securely tied up and that float switch movement is not obstructed.  
Check system operation.